

**CPT-DFM2 Card**  
**DF Series Inverter Controller Motherboard**  
**Technical Brief**

December 2017  
Manual Release 1.0  
Card Revision 1

Copyright © 2017

**Creative Power Technologies P/L**  
P.O. Box 714  
MULGRAVE  
Victoria, 3170

**CREATIVE POWER**  
**TECHNOLOGIES**

Tel: +61-3-9543-8805  
Fax: +61-3-9543-8802  
Email: [tech@creativepower.com.au](mailto:tech@creativepower.com.au)

## **CPT-DFM2 Manual Revision History**

CARD REVISION 1:            Production Release  
                                         Generated from the DFM1 REV 1 card

Release 1.00 – Initial Manual Release

## Table of Contents

CPT-DFM2 Card.....	1
DF Series Inverter Controller Motherboard.....	1
Technical Brief.....	1
1.0 DF Series Overview.....	1
1.1 DF Series Card Range .....	1
1.1.1 DF Series Control Card: .....	1
1.1.2 DF Series Peripheral Cards.....	2
1.1.3 DF Series Inverter Motherboards .....	3
1.2 DF Series Interfaces.....	4
1.2.1 Main Interface.....	4
1.2.2 Communications Interface .....	5
1.2.3 JTAG Interface .....	5
2.0 Overview of the CPT-DFM2 .....	6
2.1 Analog Inputs .....	8
2.2 Digital I/O.....	9
2.3 Position Encoder.....	9
2.4 Gate Drive Interface .....	9
2.5 Communications .....	10
2.6 On-card memory (DF Series Microcontroller Platforms).....	10
2.7 Power Supply.....	10
2.8 JTAG/programming.....	10
3.0 Specifications .....	11
3.1 DF Series Control Card Interface .....	11
3.2 Analog Inputs .....	11
3.2.1 Current Inputs .....	11
3.2.2 AC Voltage Inputs .....	12
3.2.3 AC/DC Voltage Input .....	12
3.3 Digital Inputs .....	13
3.3.1 Isolated Digital Inputs.....	13
3.4 Digital Outputs .....	13
3.4.1 Isolated MOSFET Outputs .....	13
3.4.2 Relay Outputs .....	13
3.5 Position Encoder Digital Inputs.....	14
3.6 PWM Gate Drive Interface .....	14
3.7 General .....	15
3.8 Power Supply.....	15
3.9 Order Codes.....	15
Appendices .....	16
Appendix A Component Layout.....	17
Appendix B Connector Pinouts .....	18
Appendix C Test Points on CPT-DFM2.....	24
Appendix D Texas Instruments Technical Manuals for Control Card MCU.....	24

## DF Series Concept

### 1.0 DF Series Overview

The DF Series provides a modular, flexible integrated inverter controller platform through a range of interconnected cards. This structure provides an overall reduction in the footprint of the inverter, as well as providing a level of flexibility to support inverters rated from 1kW to 100kW+.

The DF Series Control Card supports Texas Instruments PTP footprint based Piccolo and Delfino Microcontrollers (MCU). Creative Power is actively supporting a subset of these MCU variations as their feature sets are closely aligned. The latest range of MCUs support TI's new integrated analog and control peripherals that are designed to consolidate additional functionality within the MCU.

The modular nature of the DF Series system is seen through the flexible DF Series Interface which connects the DF Series Control Card to a wide range of peripheral cards. These cards include an Inverter Controller and various Communications Peripheral cards. Figure 1-1 shows the general structure of the DF Series stack, with the Control Card mounted to the Inverter Motherboard and any number of Communications Peripheral Cards mounted above.

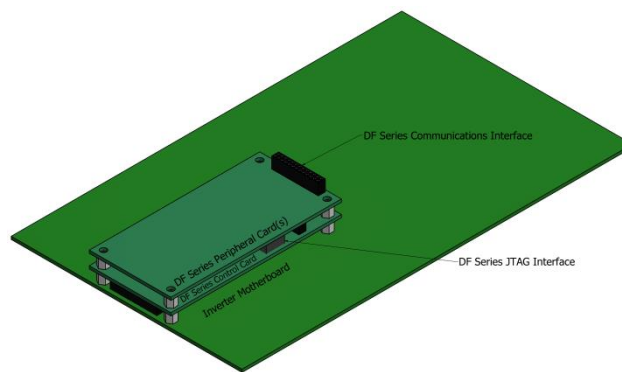

Figure 1-1: DF Series Card Stack Conceptual Overview

### 1.1 DF Series Card Range

The following is a list of the available cards within the DF Series. Additional cards will be added to the range as they become available.

#### 1.1.1 DF Series Control Card:

The DF Series Control Card is available with the following part numbers:

- **CPT-DF28075 (TMS320F28075PTP MCU Processor)**
- CPT-DF28374S (TMS320F28374SPTP MCU Processor)
- CPT-DF28375S (TMS320F28375SPTP MCU Processor)
- CPT-DF28376S (TMS320F28376SPTP MCU Processor)
- **CPT-DF28377S (TMS320F28377SPTP MCU Processor)**
- CPT-DF28374D (TMS320F28374DPTP MCU Processor)
- CPT-DF28375D (TMS320F28375DPTP MCU Processor)
- CPT-DF28376D (TMS320F28376DPTP MCU Processor)
- **CPT-DF28377D (TMS320F28377DPTP MCU Processor)**

The part number corresponding to the DF Series Control Card must be specified as part of the order. The parts in bold are CPT standard load options.

The Control Card has a footprint of 96mm x 46mm (standard DF Series Footprint size)

### **1.1.2 DF Series Peripheral Cards**

The Peripheral Cards are mounted above the Control Card within the DF Stack, with interconnection through either the DF Communications Interface or, for the CPT-DFJ, the DF JTAG interface.

All Peripheral Cards are the standard DF Series Footprint size of 96mm x 46mm.

#### **1.1.2.1 CPT-DFC1**

CPT-DFC1 Peripheral Card provides external communications interfaces for the Control Card. It interfaces to the Control Card via the 26 way DF Communications Interface.

The CPT-DFC1 Peripheral Card supports the following functionality:

- Dual SCI to Isolated single USB Interface (two serial ports within the one USB connection)
  - USB-A: On-Card DIP Switch Selectable between SCIA and SCIC
  - USB-B: On-Card DIP Switch Selectable between SCIB and SCID
- Isolated CAN Interface
  - On-Card DIP Switch Selectable between CANA and CANB
- Isolated SPI Interface (isoSPI configuration)
  - Direction Selection: On-Card DIP Switch Selectable between Master/Slave
  - Mode Selection: On-Card DIP Switch Selectable Phase and Offset – SPI Modes 0-3
- Real-Time Clock (I<sup>2</sup>C) with Supercapacitor backup

#### **1.1.2.2 CPT-DFC2**

CPT-DFC2 Peripheral Card provides external communications interfaces for the Control Card. It interfaces to the Control Card via the 26 way DF Communications Interface.

The CPT-DFC2 Peripheral Card supports the following functionality:

- Dual SCI to Isolated single USB Interface (two serial ports within the one mini-USB or USB Type A connection)
  - USB-A: On-Card DIP Switch Selectable between SCIA and SCIC
  - USB-B: On-Card DIP Switch Selectable between SCIB and SCID
- Isolated CAN Interface
  - On-Card DIP Switch Selectable between CANA and CANB
- Real-Time Clock (I<sup>2</sup>C) with Supercapacitor backup
- µSD Card reader for data logging on the SCIA transmit signal from the MCU.

#### **1.1.2.3 CPT-DFC4**

CPT-DFC4 Peripheral Card provides external communications interfaces for the Control Card. It interfaces to the Control Card via the 26 way DF Communications Interface.

The CPT-DFC4 Peripheral Card supports the following functionality:

- Isolated RS422/RS485 Interface
  - On-Card DIP Switch Selectable between SCIB and SCID
  - On-Card DIP Switch Selectable between RS422 and RS485 Mode
- Isolated CAN Interface
  - On-Card DIP Switch Selectable between CANA and CANB
- Isolated SPI Interface (isoSPI configuration)
  - Direction Selection: On-Card DIP Switch Selectable between Master/Slave
  - Mode Selection: On-Card DIP Switch Selectable Phase and Offset – SPI Modes 0-3
- µSD Card reader for data logging on the SCIA transmit signal from the MCU.

#### **1.1.2.4 CPT-DFJ**

- JTAG + SCI to Isolated single USB Interface
  - USB based UART Serial Port through MCU Port SCIA
  - USB JTAG Emulation interface for programming and debugging of the Control Card

### 1.1.3 DF Series Inverter Motherboards

The CPT-DFM1 and CPT-DFM2 are Creative Power's next generation high performance MCU based inverter controller motherboards. They have been designed to provide flexibility of connection, combined with a minimum footprint for applications requiring an integrated solution to control up to a four-phase leg VSI stack (DFM1) or eight-phase leg VSI stack (DFM2).

The Inverter Motherboard is compatible with the DF Series Control Cards, and the CPT-DFM1/Control Card Platform combination contains on-card all necessary functions for a complete standalone inverter control system.

#### 1.1.3.1 CPT-DFM1

The CPT-DFM1 Inverter Motherboard supports up to 8 plug/solder-in gate driver modules, enabling the system to be scaled to an applications specific topology and power rating. This board is designed for power stages up to around 10kW as standard. Higher power operation requires discussion with CPT.

The card has the following features:

- DF Series Main Interface Connectors
- 11 off Conditioned Analog Inputs (Low voltage inputs):
  - 3 off differential AC voltage inputs, (Three-phase 4 wire input compatible)
  - 3 off differential AC/DC voltage inputs
  - 5 off current inputs (AC and DC compatible)
- Isolated Digital I/O
  - 2 off isolated digital inputs (Field supply)
  - 3 off MOSFET switch isolated outputs
  - 2 off relay output, c/o contact
- On-Card Status Indication
  - 1 off Power LED
  - 4 off indication LEDs
  - Each isolated Digital I/O has an on-card status LED
- 4 off DIP switches
- 8 off CPT-Gxx compatible gate driver interface.
  - 3.3V TTL ePWM compatible outputs
  - Driven by ePWM1x to ePWM4x via the DF Series Main Interface
  - 2 sets of 4 fault feedback interrupt
  - Supports CPT's range of CPT-Gxx gate driver boards
  - Switched Gate Driver Supplies to drive isolating transformers on CPT-Gxx gate driver boards
  - Gate Driver Reset signal
- Quadrature Position Encoder input with Index and Strobe
- Push button reset
- On-card logic level supply generation
- Power supply operation from input 24VDC

The CPT-DFM1 card measures 220mm x 130mm.

### 1.1.3.2 CPT-DFM2

The CPT-DFM2 Inverter Motherboard supports up to 16 external gate driver signals, enabling the system to be scaled to an applications specific topology and power rating. This board is designed for higher power applications than the CPT-DFM1 and is designed to interface with off-card Gate Driver Modules such as the CPT-E02, which contains 3 SKYPER 32 PRO modules to drive a 3 phase VSI power stage.

The card has the following features:

- DF Series Main Interface Connectors
- 11 off Conditioned Analog Inputs (Low voltage inputs):
  - 3 off differential AC voltage inputs, (Three-phase 4 wire input compatible)
  - 3 off differential AC/DC voltage inputs
  - 5 off current inputs (AC and DC compatible)
- Isolated Digital I/O
  - 3 off isolated digital inputs (Field supply)
  - 3 off MOSFET switch isolated outputs
  - 2 off relay output, c/o contact
- On-Card Status Indication
  - 1 off Power LED
  - 4 off indication LEDs
  - Each isolated Digital I/O has an on-card status LED
- 4 off DIP switches
- 16 off TTL compatible gate driver interface.
  - 5V TTL ePWM compatible outputs
  - Driven by ePWM1x to ePWM8x via the DF Series Main Interface
  - 2 sets of 8 fault feedback interrupt
  - Gate Driver Reset signal
  - 2 output connectors
- Quadrature Position Encoder input with Index and Strobe
- Push button reset
- On-card logic level supply generation
- Power supply operation from input 24VDC

The CPT-DFM2 card measures 220mm x 100mm.

## 1.2 DF Series Interfaces

The DF Series is modular in construction, which implies that signals require connection between the various cards. This is achieved using 2mm Dual-inline connectors between the cards within the DF Series Stack.

The Control Card consists of three Interface types:

- DF Series Main Interface (2 x 26-way + 3 x 20-way 2mm Dual-inline connectors)
- DF Series Communications Interface (26-way 2mm Dual-inline connector)
- DF Series JTAG Interface (10-way 2mm Dual-inline connector)

### 1.2.1 Main Interface

The DF Series Main Interface provides signal connection between the Control Card and Inverter Motherboard (CPT-DFM2). It is located on the underside of the Control Card.

The DF Series Main Interface has been broken up into 5 separate connectors. The Analog connector is located along the left hand edge of the Control Card and Motherboard. The remaining 4 connectors contain digital signals between the Control Card to the Motherboard. Their precise functionality must be specified within the user software to suit the Motherboard.

## CPT-DFM2 INVERTER CONTROLLER MOTHERBOARD TECHNICAL BRIEF

The Inverter Motherboard is configured as the base of the Main Interface Stack. The Control Card is mounted above the Inverter Motherboard.

### 1.2.2 *Communications Interface*

The DF Series Communications Interface provides signal connection between the Control Card and DFC Series Peripheral Cards. The Communications Interface is located along the right hand edge of the DF Series Footprint cards.

The Control Card is configured as the base of the Communications Interface stack. All Peripherals cards are mounted above the Control Card.

### 1.2.3 *JTAG Interface*

The DF Series Control Card has a 10 way connector that interfaces to the isolated CPT-DFJ JTAG and SCI USB card.

The isolated JTAG and SCI card is compatible with TI's default JTAG software EEPROM specification and provides a fully isolated USB JTAG Interface with a Serial Communications Interface to SCIA on the MCU.

## CPT-DFM2 Inverter Controller Motherboard

### 2.0 Overview of the CPT-DFM2

The CPT-DFM2 is Creative Power's next generation high performance MCU based inverter controller motherboard. The CPT-DFM2 has been designed to provide flexibility of connection, combined with a minimum footprint for higher power applications (10kW+) requiring an integrated solution to control up to an eight-phase leg VSI stack.

The board is compatible with the DF Series range of Control Cards that are based around the Texas Instruments Piccolo TMS320F2807x and Delfino TMS320F2837xS and TMS320F2837xD MCU range. These Microcontrollers has been specifically developed for use in digital motor/motion control applications, and the CPT-DFM2/Control Card combination contains on-card all necessary functions for a complete standalone inverter control system.

The CPT-DFM2 card measures 220mm x 100mm.

On-card facilities include:

- DF Series Main Interface Connectors
- Conditioned Analog Inputs (Low voltage inputs):
  - 3 off differential AC voltage inputs, (Three-phase 4 wire input compatible)
  - 3 off differential AC/DC voltage inputs
  - 5 off current inputs (AC and DC compatible)
- Isolated Digital I/O
  - 3 off isolated digital inputs (Field supply)
  - 3 off MOSFET switch isolated outputs
  - 2 off relay output, c/o contact
- On-Card Status Indication
  - 1 off Power LED
  - 4 off indication LEDs
  - Each isolated Digital I/O has an on-card status LED
- 4 off DIP switches
- 8 off CPT-Gxx compatible gate driver interface.
  - 5V TTL ePWM compatible buffered outputs
  - Driven by ePWM1x to ePWM8x via the DF Series Main Interface
  - 2 sets of 8 fault feedback interrupts
  - Connector supports CPT-E02 gate driver card
  - Standardised 0.1" IDC Interface
  - Gate Driver Reset signal
- Quadrature Position Encoder input with Index and Strobe
- Push button reset
- On-card logic level supply generation
- Power supply operation from input 24VDC

Figure 2-1 shows a functional block diagram of the CPT-DFM2 card, illustrating all major sections.

CPT- DFM2 INVERTER CONTROLLER BOARD TECHNICAL BRIEF

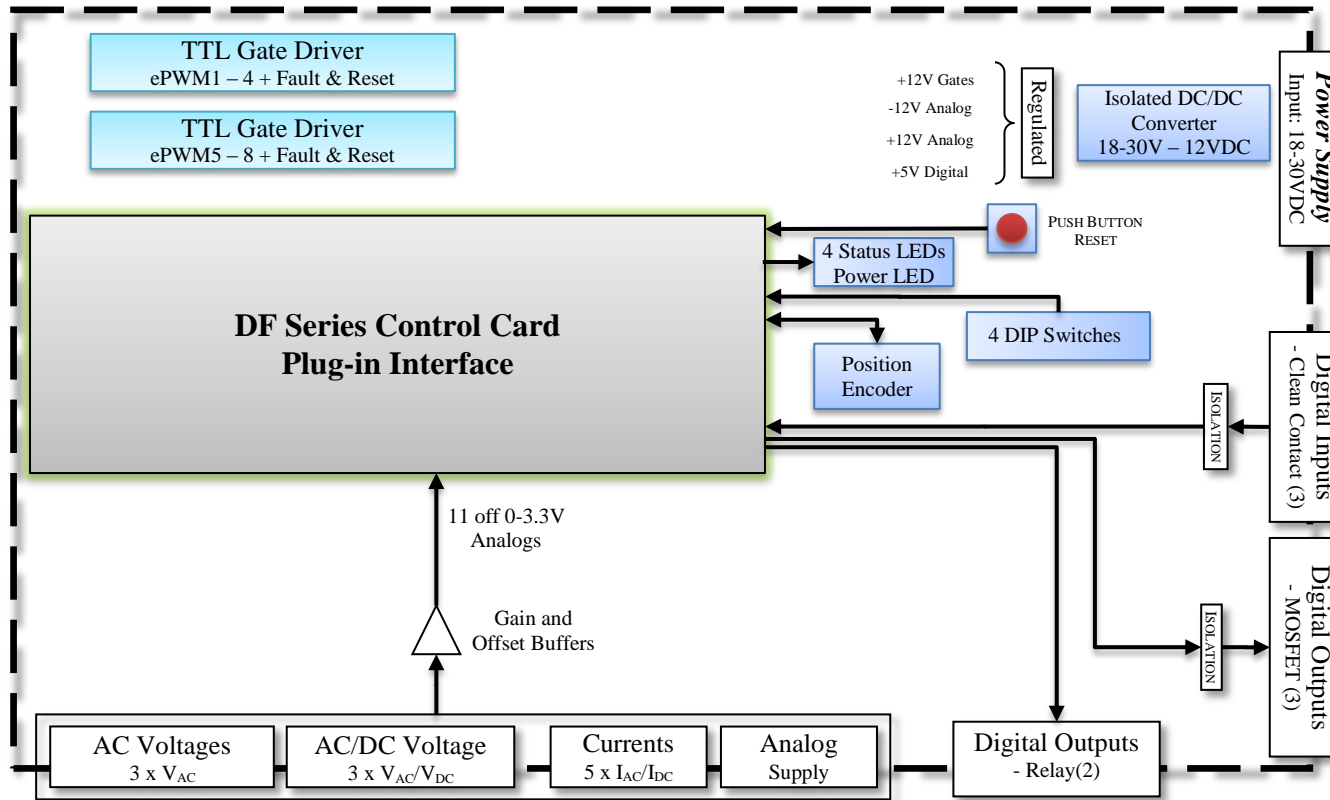

Figure 2-1: Functional Diagram of CPT-DFM2 Inverter Controller Board

### 2.1 Analog Inputs

The DF Series MCU Platform has ADC inputs that accept voltages in the range of 0 - 3.3V ( $V_{DDA}$ ). The analog inputs are spread across the four ADC modules (ADCINA2-5, ADCINB1-3, ADCIN14, ADCINC2, ADCINC4 and ADCIND0-2). Each module has an analog multiplexer with its own sample and hold circuit. The output from the sample and hold circuit is fed directly into the Module's 12-bit converter.

Please consult the Texas Instruments documentation on the Analog Subsystem relevant to the MCU Platform used within the system for further information. *TMS320F2807x Piccolo Microcontrollers Technical Reference Manual*, Literature Number: *SPRUHM9*, *TMS320F2837xS Delfino Microcontrollers Technical Reference Manual*, Literature Number *SPRUHX5A* or *TMS320F2837xD Dual-Core Delfino Microcontrollers Technical Reference Manual*, Literature Number *SPRUHM8C*.

There are eleven (11) analog inputs on the CPT-DFM2 board that are configured as 5 off AC/DC currents, 3 off AC voltages and 3 off AC/DC voltages. The signals are conditioned to 0 – 3.3V for the DF Series interface. Two current signals are also fed to the ADCC comparator inputs on the DF Series interface. The MCU Platforms have a low pass “glitch” filter and a diode clamp circuit on each ADC input before the signals are fed into the MCU.

The five current inputs are designed to operate with an off-card CT or LEM module. The current inputs are configured for operation with a voltage input signal, such as supplied from a current transducer. The current inputs are differential signals with each input able to be connected using individual twisted pair wires. An earth shield can be connected to the mounting holes adjacent to the analog inputs. The use of a differential input reduces the impact of cable noise injection on the measured signal. The default current input configuration requires any offset voltage to be added to the differential input. An optional offset capability is available on-card. Current Inputs I1 – I3 have a voltage range of 1.7 and 3.3V, and current inputs I4 – I5 have a voltage range of 2.45 – 3.3V. If a CT or current output LEM modules are used then burden resistors should be placed at the transducer to convert the signal to an equivalent voltage. The offset circuitry on-card would need to be modified to suit. In addition the current inputs have a software configurable overcurrent trip capability using the MCU's comparator subsystem functionality.

The three AC voltage inputs are differential high impedance circuits, allowing line-line AC voltages to be measured from a three-phase four wire system. The board's on-card resistors are rated for a  $\pm 10V$  peak, and off-card series resistors should be added for higher voltage ranges.

The three AC/DC voltage inputs are configured for bidirectional voltage input on the default board load. They are a differential high impedance circuit, allowing the voltage to be measured between two floating rails. Each input has an offset stage that can be individually tuned to provide a tailored voltage input range by loading alternative components. The default board load has a  $\pm 10V$  voltage range for these inputs.

### 2.2 Digital I/O

The CPT-DFM2 card supports 15 bits of digital I/O, consisting of 8 bits for local I/O and 8 bits interfacing to external circuitry.

The local I/O consists of 4 bits driving on-card LEDs (**H6, H7, H8, H9**) and 4 bits of DIP switch inputs (**S2**).

The isolated I/O consists of 3 off isolated digital inputs, 2 off relay output (changeover contact) and 3 off isolated MOSFET outputs.

The isolated digital inputs can be driven using the +24V input supply or an off-card supply referenced to the input supply ground. An LED is provided on the isolated side of each input as a visual indication of its state.

The 2 off relay outputs have single pole changeover contacts capable of driving 10A 240Vac or 1A 24Vdc. An LED is provided on the coil side of the output as a visual indication of its state.

The 3 off MOSFET outputs are powered from the +24V input supply. An LED is provided on the isolated side of the output as a visual indication of its state.

Note: The ePWM1-8 signals on the Gate Driver IDC connectors can also be configured as digital I/O. Due to the on-card buffer they must be used as digital outputs. This provides up to 16 additional digital outputs. Further Digital I/O expansion is supported through the SPI interface on the DF Series Communications Header.

### 2.3 Position Encoder

The position encoder interface accepts quadrature encoded pulses from a relative position encoder system, and passes these pulses to the Quadrature decoder unit (QDU) within the MCU.

A separate index pulse input (QEPI) can be used to generate an interrupt to reset this counter for synchronisation. Typically this is used to indicate absolute position on a once per revolution basis.

A strobe signal input (QEPS) is supported by the eQEP module. This signal typically acts as an indicator that the motor has reached a defined position. It is not required for basic operation of the eQEP interface.

The encoder input signals are +5V TTL compatible, referenced to the on-card ground and diode clamped to avoid damage caused by input over voltages.

### 2.4 Gate Drive Interface

The TMS320F2807x and TMS320F2837xS/TMS320F2837xD MCUs support up to 12 ePWM Type 4 modules. Each ePWM module represents one complete PWM channel. A channel contains two PWM outputs, defined as ePWMxA and ePWMxB. Specific details of the ePWM Type 4 module functionality is provided within the MCU processor manuals available from Texas Instruments.

The default CPT-DFM2 board supports 8 ePWM modules from the DF Series Interface.

Four of these ePWM modules ePWM1-4 are available through the 20-way IDC header **X16**, and four more ePWM5-8 are available through the 20-way IDC header **X17**. These signals are provided at 5V TTL level fully buffered from the MCU. In addition the headers contain a digital input and a digital output, typically used as a fault status feedback and a gate reset signal as well as a 5V logic supply.

The CPT-E02 board range has a header that is compatible with these IDC interfaces. The CPT-E02 card provides an isolated gate driver interface for up to 6 outputs in its default configuration. Variations of this card have been design for other gate driver combinations. The CPT-E02 has the same footprint and mounting holes as the CPT-DFM2 base board allowing the two to be connected as a stack. This mounting configuration provides an integrated and easily serviceable gate driver module functionality for power stages at >10kW power levels.

### 2.5 Communications

The CPT-DFM2 card does not directly support external communications. These interfaces are available on the DF Series Microcontroller Platform and feed to the Peripheral Communications Cards.

The DF Series Communications Interface supports four communication protocols: four off non-isolated LVTTTL (3.3V) serial communications interfaces (SCI), an LVTTTL synchronous serial peripheral interface (SPI), two off CAN-Bus Ports and an I2C interface.

Refer to the specific peripheral card manuals for implementation details on these interfaces.

### 2.6 On-card memory (DF Series Microcontroller Platforms)

The CPT-DFM2 is designed for operation with a plug-in DF Series MCU Platform.

The DF Series MCU Platforms support up to 512k x 16-bit of on-card Flash, 102k x 16-bit of SARAM, a Boot ROM and 2k x 16 bit OTP Memory.

User programs can be directly executed from RAM, via the CPT-DFJ Isolated USB JTAG interface board or from internal Flash. By default, the control cards execute software from flash memory. Solderable resistor links are provided on the control card to enable selection of the Boot Mode from either a boot loader, RAM, flash, SCI or the SPI.

In addition to the on-chip memory the DF Series MCU Platforms have a 1Mbit SPI interfaced Flash Memory chip for external data storage. Options are available for 2Mbit, 4Mbit, 8Mbit and 16Mbit Serial Flash chips.

### 2.7 Power Supply

The CPT-DFM2 board is operates from a nominal +24VDC input supply voltage. The board supports operation over the range of +18 to +30VDC.

The card has an isolated DC/DC converter to generate a nominal +12V that is used to create all of the local regulated supplies required by the card. Note that the isolated digital I/O uses the +24V supply for its purposes. Therefore it is strongly recommended to maintain the supply voltage within the acceptable range of operation for the MOSFET digital outputs and clean contact digital inputs.

### 2.8 JTAG/programming

The DF Series Control Cards are programmable via a JTAG interface. The CPT-DFJ isolated JTAG card provides a JTAG to USB emulator/debugging interface compatible with Texas Instruments Code Composer Studio. This USB interface also contains an SCI port (SCI-A) which can be used as a console.

### 3.0 Specifications

#### 3.1 DF Series Control Card Interface

Interrupts	<p>The DF Series Main Interface supports interrupts on all GPIO pins.</p> <p>The CPT-DFM2 can use the following pins as interrupts GPIO22 and GPIO23.</p> <p>GPIO23 is the gate fault feedback for CPT-Gxx modules 1 to 4 (active LOW – fault)</p> <p>GPIO22 is the gate fault feedback for CPT-Gxx modules 5 to 8 (active LOW – fault)</p>
------------	---------------------------------------------------------------------------------------------------------------------------------------------------------------------------------------------------------------------------------------------------------------------------------------------------------------------------------------------

#### 3.2 Analog Inputs

Number of Channels	17 - TMS320F28075 (maximum of 20 on the TMS320F2837xx)
A/D Resolution	12 bits
A/D Conversion Time	290ns
Number of ADC Modules	3 - TMS320F28075 (4 on the TMS320F2837xx)
Number of S/H units	1 per Module

##### 3.2.1 Current Inputs

Definition	5 off twisted pair 2-wire CT & LEM compatible current inputs
MCU ADC Channels	I1: ADCINA14, I2: ADCINA2, I3: ADCINA4, I4: ADCINA3, I5: ADCINA5
Input Voltage Range	<p>I1 to I3: 1.7 – 3.3V maximum – Assuming zero input corresponds to 2.5V (LTS15-NP full range +/-18.75A peak)</p> <p>I4 to I5: 2.46 – 3.3V maximum – Assuming zero input corresponds to 2.5V (LTS15-NP full range -1/+18.75A peak)</p>
Burden Resistor	Must be mounted off-card. The input must be provided as a voltage.
Voltage Driven LEM	<p>Default: Any offset present in the LEM output must be compensated off-card</p> <p>Option: DNL Resistors on-card for separately conversion of each input to support a +2.5V offset.</p>
Offset	<p>I1 to I3 have a common offset reference– set by <b>R89</b> at 50% of the rated peak-peak input</p> <p>I4 to I5 have a common offset reference – set by <b>R92</b> at ~5% of the rated peak-peak input</p>
Overcurrent Protection	<p>Requires software programming</p> <p>Supported via the built-in ADC Comparator operations within the MCU</p> <p>I1 (CMPIN4P), I2 (CMPIN1P), I3 (CMPIN2P), I4 (CMPIN6P), I5 (CMPIN5P)</p>
Supply for Off-card	±12V, +5V available on <b>X9</b>
Dynamic Response	Cut-off frequency >150kHz
PCB Connections	<p>I1 to I3 – 6-way Phoenix PTSM Series 2mm connector</p> <p>Designed for individual twisted pair connection (labelled as <b>X11</b>)</p> <p>I4 to I5 – 6-way Phoenix PTSM Series 2mm connector.</p> <p>Designed for individual twisted pair connection (labelled as <b>X10</b>)</p> <p>Both right angled and vertical headers are supported by the board.</p>

## CPT-DFM2 INVERTER CONTROLLER BOARD TECHNICAL BRIEF

### 3.2.2 AC Voltage Inputs

Definition	3 off AC voltage differential analog inputs, V1 to V3: ADCIND0 – ADCIND2
Input Voltage Range	±10 Vac maximum peak (on-card)
Measurement	10V rated Differential Input.
Off-Card Resistors	Differential resistor chains may be added off-card to increase the effective measured voltage range
Zero Crossing Detection	Supported via the built-in ADC Comparator operations within the MCU Software configurable via CMPIN7P on VAC1 Software configurable via CMPIN8P on VAC3
Offset	V1 to V3 have a common offset reference. By default it is set to 50% of the input range. V1 – V3: Set by <b>R58</b>
Dynamic Response	Cut-off frequency > 450kHz
PCB Connections	4-way Phoenix PTSM Series 2mm connector ( <b>X13</b> ) Both right angled and vertical headers are supported by the board.

### 3.2.3 AC/DC Voltage Input

Definition	3 off AC/DC voltage differential analog input, V4 to V6: ADCINB3 – ADCINB1 Configured by default for DC input, with 10% reverse polarity detection.
Input Voltage Range	±10 Vac maximum peak (on-card)
Measurement	10V rated Differential Input.
Off-Card Resistors	Differential resistor chains may be added off-card to increase the effective measured voltage range
Offset	V4 to V6 have individual offset references. By default these are set to 50% of the input range. V4: Set by <b>R59</b> V5: Set by <b>R62</b> V6: Set by <b>R63</b>
Over-Voltage Detection	Supported via the built-in ADC Comparator operations within the MCU Software configurable for V5 on CMPIN3P
Dynamic Response	Cut-off frequency >450kHz
PCB Connections	6-way Phoenix PTSM Series 2mm connector ( <b>X12</b> ) Both right angled and vertical headers are supported by the board.

### 3.3 Digital Inputs

#### 3.3.1 Isolated Digital Inputs

Definition	3 bits of optically isolated digital inputs, clean contact compatible (GPIO44, GPIO45, GPIO35)
Minimum Input Voltage	12V DC
Maximum Input Voltage	30V DC
Dynamic Response	0.1ms propagation delay 0-24V rising input 2ms propagation delay 24-0V falling input
Isolation	Optical Isolation Withstand Voltage: 1500V peak (1 minute) Between GND_F and GND. Note that GND_F is the input supply voltage ground. All Isolated Digital Inputs and MOSFET Outputs are on a common ground.
PCB Connections	3-way Phoenix MCV1,5 3.81mm spacing connector, with signal, signal ground and a +24V field supply ( <b>X2, X3, X15</b> )

### 3.4 Digital Outputs

#### 3.4.1 Isolated MOSFET Outputs

Definition	3 off optically isolated MOSFET switched outputs (GPIO34, GPIO33, GPIO32)
$I_{source}$	2.4mA @24V, through 10k $\Omega$ pull up resistor
$I_{sink}$	300mA nominal 1A absolute maximum <sup>Note 1</sup>
Switch Configuration	Single pole, normally open. Direct connection to input supply ground
Isolation	Isolation Withstand Voltage to GND: 1500V peak (1 minute) Between GND_F and GND. Note that GND_F is the input supply voltage ground. All Isolated Digital Inputs and MOSFET Outputs are on a common ground.
PCB Connections	3-way Phoenix MCV1,5 3.81mm spacing connector, with signal, signal ground and a +24V field supply ( <b>X4, X5, X6</b> ).

Note 1: Only one MOSFET output used.

#### 3.4.2 Relay Outputs

Definition	2 off Changeover Relay Outputs (GPIO31, GPIO30)
Contact Ratings	240V, 10A AC 30V, 10A DC
Contact Configuration	Single Pole, changeover
Isolation Withstand	3kV AC
Relay Coil Power Supply	Supplied from on-card 12V supply
PCB Connections	3-way Phoenix MCV1,5 3.81mm spacing connector, with normally open, normally closed and common terminals ( <b>X8, X7</b> ).

### 3.5 Position Encoder Digital Inputs

Definition	1 pair of quadrature encoded pulses defining relative position change (GPIO50, GPIO51) 1 index pulse (GPIO53), 1 strobe pulse (GPIO52)
Minimum Input Voltage	0V DC (TTL low)
Maximum Input Voltage	+5V DC (TTL high)
Input Protection	Diode clamped to GND and +5V, Schmitt trigger buffered input, 1k0 input impedance
PCB Connection	6-way MOLEX 0.1" connector, with signals, logical ground and a +12V unisolated supply ( <b>X14</b> )

### 3.6 PWM Gate Drive Interface

Definition	16 PWM Outputs, defined on card as modules ePWM1 to ePWM8. These PWM outputs are sourced from the ePWM outputs 1 to 8 available on the DF Series interface (GPIO0 – GPIO15). ePWM outputs 1 – 4 (8 signals) are available on <b>X16</b> . ePWM outputs 5 – 8 (8 signals) are available on <b>X17</b> .
ePWM Module	Each ePWM module consists of two PWM outputs (EPWMxA and EPWMxB) that can be used in the following configurations: – Two independent PWM outputs with single-edge operation – Two independent PWM outputs with dual-edge symmetric operation – One independent PWM output with dual-edge asymmetric operation
Gate Fault Interrupts	The <b>X16</b> connector has a fault feedback signal, FAULT1*, which can be configured within the MCU to a Trip Zone (TZ) for any of the ePWM modules. The <b>X17</b> connector has a fault feedback signal, FAULT2*, which can be configured within the MCU to a Trip Zone (TZ) for any of the ePWM modules. A fault trip places the PWM signals into a high impedance state. The DFM2 contains 2k2 pull down resistor that feed into the level shifting buffer to ensure the signals are LOW in the presence of a fault. If a high output is required as the response to a fault, remove the pull down resistor and enable the internal GPIO pull-up within the MCU. Trip Zones are interrupts that when activated can immediately disable the ePWM Modules. Response time is a minimum of 3*TBCLK low pulse width on the TZ input for detection.
Gate Reset	Normally Low Gate Reset Signals, SW_G1_RESET* (GPIO25) and SW_G2_RESET* (GPIO26)
Output Voltage	0-5V
PCB Connections	2 x 20-way IDC header ( <b>X16 &amp; X17</b> ) Note also supports IDC Socket mounted on the underside of the card for <b>X16</b> (Samtec part number ESW-110-24-G-D)

## CPT-DFM2 INVERTER CONTROLLER BOARD TECHNICAL BRIEF

### 3.7 General

Physical Dimensions	L: 220mm
	W: 100mm
	H: 22mm approx. without connectors H: 28mm approx. with dual stack DMF and connectors
Mounting Arrangement	8 off 3.5 mm holes – please consult the mechanical layout diagram in the appendix for full details
Environmental	-20 – 60°C ambient operating temperature 5% - 95% non-condensing humidity

### 3.8 Power Supply

Input Voltage Range	18 – 30VDC	
Standalone Input Current	<b>1 – 2A</b> (depending on the active sections within the MCU and supply voltage)	
Max Input Power	Approx. <b>40W</b>	
Protection	1.5A Fuse ( <b>F1</b> ) for Control Power 1.5A Fuse ( <b>F2</b> ) for “Field” supply digital I/O Replacement part: Littelfuse 045201.5NRL	
Supplies Generated on-card	GND_GATE (EARTH)	+12V_GATE (+12V) Gate Driver Power Supply
	GND Digital Ground Analog Ground	+12V_DIG (+12V) used for generating digital on-card regulated positive power supplies
		+12V Analog Supply
		-12V Analog Supply
		+5V Digital Supply
		+3.3V Digital
		+2.5V Analog Reference
Input Power Connector	3-way Phoenix MCV 3,81mm spacing connector with +24V, GND, EARTH. ( <b>X1</b> )	

### 3.9 Order Codes

Base Part Number	CPT-DFM2
------------------	----------

## **Appendices**

Appendix A Component Layout

Top Layer

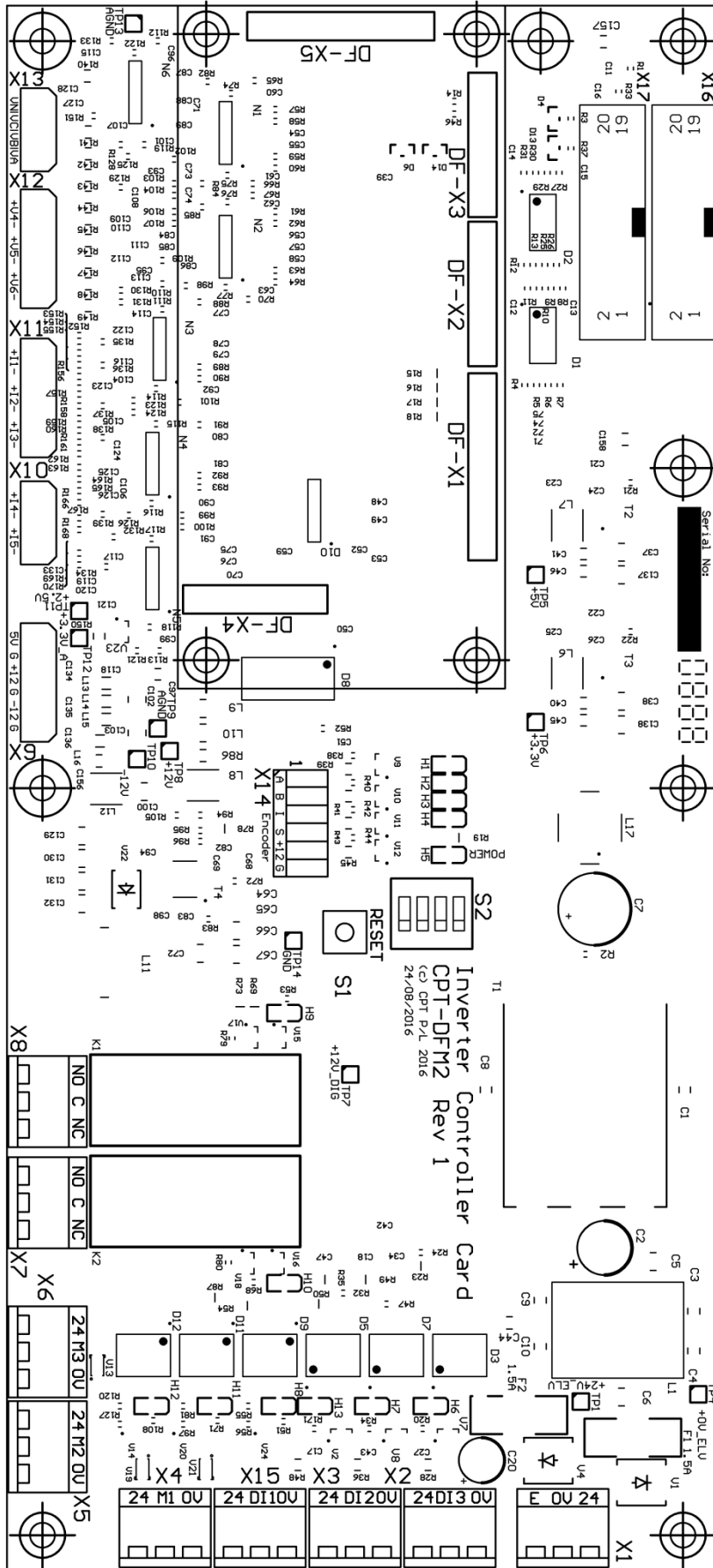

**Appendix B Connector Pinouts**

Conn. No.	Connector Type	Pin No.	Signal Name	Comment
<b>Analogs – Voltages 4 - 6</b>				
X12	Phoenix PTSM Series 2.5mm Spacing	1	V4+	Positive Voltage 4 Input
		2	V4-	Negative Voltage 4 Input
		3	V5+	Positive Voltage 5 Input
		4	V5-	Negative Voltage 5 Input
		3	V6+	Positive Voltage 6 Input
		4	V6-	Negative Voltage 6 Input
<b>Analogs – AC Voltage</b>				
X13	Phoenix PTSM Series 2.5mm Spacing	1	VN	AC Voltage Input (Common Differential Channel)
		2	VC	AC Voltage Input
		3	VB	AC Voltage Input
		4	VA	AC Voltage Input
<b>Analogs – Currents I1 to I3</b>				
X11	Phoenix PTSM Series 2.5mm Spacing	1	I1_IN	I1 Current Input
		2	I1_GND	I1 Ground
		3	I2_IN	I2 Current Input
		4	I2_GND	I2 Ground
		5	I3_IN	AC 3 Current Input
		6	I3_GND	I3 Ground
<b>Analogs – Currents I4 to I5</b>				
X10	Phoenix PTSM Series 2.5mm Spacing	1	I4_IN	I4 Current Input
		2	I4_GND	I4 Ground
		3	I5_IN	I5 Current Input
		4	I5_GND	I5 Ground
<b>Analogs – Power SUPPLY</b>				
X9	Phoenix PTSM Series 2.5mm Spacing	1	+12V_OC	+12V Supply
		2	AGND_OC	Analog Ground
		3	-12V_OC	-12V Supply
		4	AGND_OC	Analog Ground
		5	+5V_LEM_OC	Filtered +5V
		6	AGND_OC	Analog Ground - Filtered
<b>Position Encoder Interface</b>				
X14	MOLEX 6 WAY	1	QEPA	Quadrature Encoded Pulse
		2	QEPB	Quadrature Encoded Pulse
		3	QEPI	INDEX pulse
		4	QEPS	STROBE pulse
		5	+12V_DIG	+12V Supply
		6	GND	Digital Ground

**CPT- DFM2 INVERTER CONTROLLER BOARD TECHNICAL MANUAL**

**Power Supply Input**

<b>X1</b>	Phoenix MCV 1,5 Series	1	EARTH	EARTH Connection
		2	+0V_ELX	+24V Supply Ground (DC-)
		3	+24V_ELX	+24V Supply Positive(DC+)

<b>Conn. No.</b>	<b>Connector Type</b>	<b>Pin No.</b>	<b>Signal Name</b>	<b>Comment</b>
------------------	-----------------------	----------------	--------------------	----------------

**Isolated Digital Outputs – Relay 1**

<b>X8</b>	Phoenix MCV 1,5 Series	1	RLY1_NO	Relay 1 Normally <b>Open</b> Contact
		2	RLY1_COM	Relay 1 <b>Common</b>
		3	RLY1_NC	Relay 1 Normally <b>Closed</b> Contact

**Isolated Digital Outputs – Relay 2**

<b>X7</b>	Phoenix MCV 1,5 Series	1	RLY2_NO	Relay 2 Normally <b>Open</b> Contact
		2	RLY2_COM	Relay 2 <b>Common</b>
		3	RLY2_NC	Relay 2 Normally <b>Closed</b> Contact

**Isolated Digital Outputs – MOFSET 1**

<b>X4</b>	Phoenix MCV 1,5 Series	1	+24V_F	
		2	MOSFET_OUT1	MOSFET driven Isolated Digital Output 1
		3	GND_F	

**Isolated Digital Outputs – MOFSET 2**

<b>X5</b>	Phoenix MCV 1,5 Series	1	+24V_F	
		2	MOSFET_OUT2	MOSFET driven Isolated Digital Output 2
		3	GND_F	

**Isolated Digital Outputs – MOFSET 3**

<b>X6</b>	Phoenix MCV 1,5 Series	1	+24V_F	
		2	MOSFET_OUT3	MOSFET driven Isolated Digital Output 3
		3	GND_F	

<b>Conn. No.</b>	<b>Connector Type</b>	<b>Pin No.</b>	<b>Signal Name</b>	<b>Comment</b>
------------------	-----------------------	----------------	--------------------	----------------

**Isolated Digital Input 1**

<b>X15</b>	Phoenix MCV 1,5 Series	1	+24V_F	
		2	DIGIN1	Digital Input 1
		3	GND_F	

**Isolated Digital Input 2**

<b>X3</b>	Phoenix MCV 1,5 Series	1	+24V_F	
		2	DIGIN2	Digital Input 2
		3	GND_F	

**Isolated Digital Input 3**

<b>X2</b>	Phoenix MCV 1,5 Series	1	+24V_F	
		2	DIGIN3	Digital Input 3
		3	GND_F	

**CPT- DFM2 INVERTER CONTROLLER BOARD TECHNICAL MANUAL**

<b>Conn. No.</b>	<b>Connector Type</b>	<b>Pin No.</b>	<b>Signal Name</b>	<b>Comment</b>
<b>Gate 1– 5V TTL Module X16</b>				
<b>X15</b>	0.1" IDC 20 way	1	+5V	
		2	GND	
		3	GPIO0	GPIO0 / ePWM1A
		4	GND	
		5	GPIO1	GPIO1 / ePWM1B
		6	GND	
		7	GPIO2	GPIO2 / ePWM2A
		8	GND	
		9	GPIO3	GPIO3 / ePWM2B
		10	GND	
		11	GPIO4	GPIO4 / ePWM3A
		12	GND	
		13	GPIO5	GPIO5 / ePWM3B
		14	GND	
		15	GPIO6	GPIO6 / ePWM4A
		16	GND	
		17	GPIO7	GPIO7 / ePWM4B
		18	GND	
		19	FAULT1*	Combined Fault Feedback Signal
		20	GATE1_RESET*	Gate Reset Signal

<b>Conn. No.</b>	<b>Connector Type</b>	<b>Pin No.</b>	<b>Signal Name</b>	<b>Comment</b>
<b>Gate 1– 5V TTL Module X16</b>				
<b>X17</b>	0.1" IDC 20 way	1	+5V	
		2	GND	
		3	GPIO8	GPIO8 / ePWM5A
		4	GND	
		5	GPIO9	GPIO9 / ePWM5B
		6	GND	
		7	GPIO10	GPIO10 / ePWM6A
		8	GND	
		9	GPIO11	GPIO11 / ePWM6B
		10	GND	
		11	GPIO12	GPIO12 / ePWM7A
		12	GND	
		13	GPIO13	GPIO13 / ePWM7B
		14	GND	
		15	GPIO14	GPIO14 / ePWM8A
		16	GND	
		17	GPIO15	GPIO15 / ePWM8B
		18	GND	
		19	FAULT2*	Combined Fault Feedback Signal
		20	GATE2_RESET*	Gate Reset Signal

**CPT-DFM2 INVERTER CONTROLLER BOARD TECHNICAL MANUAL**

Note: The label in brackets within the comment refers to the DF Series Control Card GPIO pin connection that corresponds with the connector.

<b>Conn. No.</b>	<b>Connector Type</b>	<b>Pin No.</b>	<b>Signal Name</b>	<b>Comment</b>
<b><i>DF Series Main Interface: Digital Header 1</i></b>				
<b>DF-X1</b>	SQT Socket - 26-way 2mm spacing DIL	1	+5V	+5V <b>FOR</b> DF Series Control Card
		2	GND	Digital Ground
		3	+5V	+5V <b>FOR</b> DF Series Control Card
		4	GND	Digital Ground
		5	+5V	+5V <b>FOR</b> DF Series Control Card
		6	GND	Digital Ground
		7	RESET*	DF Series Reset Signal – Open collector
		8	N/C	Not Connected (GPIO67)
		9	N/C	Not Connected (GPIO68)
		10	N/C	Not Connected (GPIO69)
		11	N/C	Not Connected (GPIO70)
		12	N/C	Not Connected (GPIO71)
		13	N/C	Not Connected (GPIO72)
		14	N/C	Not Connected (GPIO74)
		15	N/C	Not Connected (GPIO75)
		16	N/C	Not Connected (GPIO76)
		17	N/C	Not Connected (GPIO77)
		18	D_SW0	Digital Input – DIP Switch 0 (GPIO78)
		19	D_SW1	Digital Input – DIP Switch 1 (GPIO79)
		20	D_SW2	Digital Input – DIP Switch 2 (GPIO80)
		21	D_SW3	Digital Input – DIP Switch 3 (GPIO81)
		22	LED0	Digital Output – LED0 (GPIO84)
		23	LED1	Digital Output – LED1 (GPIO85)
		24	LED2	Digital Output – LED2 (GPIO86)
		25	LED3	Digital Output – LED3 (GPIO87)
		26	GND	Digital Ground

<b>Conn. No.</b>	<b>Connector Type</b>	<b>Pin No.</b>	<b>Signal Name</b>	<b>Comment</b>
<b><i>DF Series Main Interface: Digital Header 2</i></b>				
<b>DF-X2</b>	SQT Socket - 20-way 2mm spacing DIL	1	EPWM1A	ePWM1A – 3.3V-TTL (GPIO0)
		2	EPWM1B	ePWM1B – 3.3V-TTL (GPIO1)
		3	EPWM2A	ePWM2A – 3.3V-TTL (GPIO2)
		4	EPWM2B	ePWM2B – 3.3V-TTL (GPIO3)
		5	EPWM3A	ePWM3A – 3.3V-TTL (GPIO4)
		6	EPWM3B	ePWM3B – 3.3V-TTL (GPIO5)
		7	EPWM4A	ePWM4A – 3.3V-TTL (GPIO6)
		8	EPWM4B	ePWM4B – 3.3V-TTL (GPIO7)
		9	GND	Digital Ground
		10	N/C	Not Connected (GPIO88)
		11	N/C	Not Connected (GPIO89)
		12	N/C	Not Connected (GPIO90)
		13	N/C	Not Connected (GPIO91)
		14	N/C	Not Connected (GPIO92)
		15	GPIO10	ePWM6A – 3.3V-TTL (GPIO10)
		16	GPIO11	ePWM6B – 3.3V-TTL (GPIO11)
		17	GPIO12	ePWM7A – 3.3V-TTL (GPIO12)
		18	GPIO13	ePWM7B – 3.3V-TTL (GPIO13)
		19	GND	Digital Ground
		20	GND	Digital Ground

**CPT- DFM2 INVERTER CONTROLLER BOARD TECHNICAL MANUAL**

Note: The label in brackets within the comment refers to the DF Series Control Card GPIO pin connection that corresponds with the connector.

<b>Conn. No.</b>	<b>Connector Type</b>	<b>Pin No.</b>	<b>Signal Name</b>	<b>Comment</b>
<b><i>DF Series Main Interface: Digital Header 3</i></b>				
<b>DF-X3</b>	SQT Socket - 20-way 2mm spacing DIL	1	GPIO14	ePWM8A – 3.3V-TTL (GPIO14)
		2	GPIO15	ePWM8B – 3.3V-TTL (GPIO15)
		3	N/C	(GPIO16)
		4	N/C	(GPIO17)
		5	N/C	(GPIO18)
		6	N/C	(GPIO19)
		7	N/C	(GPIO20)
		8	N/C	(GPIO21)
		9	GND	GND
		10	GPIO8	ePWM5A – 3.3V-TTL (GPIO8)
		11	GPIO9	ePWM5B – 3.3V-TTL (GPIO9)
		12	FAULT2*	Gate 2 Fault Feedback Signal (GPIO22)
		13	FAULT1*	Gate 1 Fault Feedback Signal (GPIO23)
		14	N/C	(GPIO24)
		15	SW_G1_RESET*	Software Gate Reset 1 (GPIO25)
		16	SW_G2_RESET*	Software Gate Reset 2 (GPIO26)
		17	N/C	(GPIO27)
		18	GND	GND
		19	GND	GND
		20	GND	GND

<b>Conn. No.</b>	<b>Connector Type</b>	<b>Pin No.</b>	<b>Signal Name</b>	<b>Comment</b>
<b><i>DF Series Main Interface – Digital Connector 4</i></b>				
<b>DF-X4</b>	SQT Socket - 20-way 2mm spacing DIL	1	RELAY1	Digital Output – RELAY1 (GPIO30)
		2	RELAY2	Digital Output – RELAY2 (GPIO31)
		3	MOSFET1	Digital Output – MOSFET1 (GPIO32)
		4	MOSFET2	Digital Output – MOSFET2 (GPIO33)
		5	MOSFET3	Digital Output – MOSFET3 (GPIO34)
		6	DIGIN3	Isolated Digital Input 3 (GPIO35)
		7	/OUTEN	Enable Digital Output Buffers (GPIO40)
		8	N/C	Not Connected (GPIO41)
		9	GND	Digital Ground
		10	MAN_RESET*	Manual Reset – Push Button <b>S1</b>
		11	EQEPA	eQEPA – Quadrature Encoder A Pulse (GPIO50)
		12	EQEPB	eQEPB – Quadrature Encoder B Pulse (GPIO51)
		13	EQEPS	eQEPS – Quadrature Encoder Strobe Pulse (GPIO52)
		14	EQEPI	eQEPI – Quadrature Encoder Index Pulse (GPIO53)
		15	DIGIN1	Isolated Digital Input 1 (GPIO44)
		16	DIGIN2	Isolated Digital Input 2 (GPIO45)
		17	N/C	Not Connected (+3.3V_MCU)
		18	GND	Digital Ground
		19	N/C	Not Connected (+3.3V_MCU)
		20	GND	Digital Ground

**CPT- DFM2 INVERTER CONTROLLER BOARD TECHNICAL MANUAL**

Note: The label in brackets within the comment refers to the DF Series Control Card GPIO pin connection that corresponds with the connector.

<b>Conn. No.</b>	<b>Connector Type</b>	<b>Pin No.</b>	<b>Signal Name</b>	<b>Comment</b>
<b><i>DF Series Main Interface – Analog Connector</i></b>				
<b>DF-X5</b>	SQT Socket - 26-way 2mm spacing DIL	1	GND	Analog Ground
		2	adc_I5	Current Input 5 for CMPIN5P (ADC_C4)
		3	N/C	Not Connected (ADC_C3)
		4	adc_I4	Current Input 4 for CMPIN6P (ADC_C2)
		5	GND	Analog Ground
		6	adc_I5	Not Connected (ADC_A5)
		7	adc_I3	Current Input 3 (ADC_A4)
		8	adc_I4	Current Input 4 (ADC_A3)
		9	adc_I2	Current Input 2 (ADC_A2)
		10	N/C	Not Connected (ADC_A1)
		11	N/C	Not Connected (ADC_A0)
		12	GND	Analog Ground
		13	adc_I1	Current Input 1 (ADC_I4)
		14	N/C	Not Connected (ADC_I5)
		15	GND	Analog Ground
		16	N/C	Not Connected (ADC_B0)
		17	adc_V6	Voltage Input 6 (ADC_B1)
		18	adc_V5	Voltage Input 5 (ADC_B2)
		19	adc_V4	Voltage Input 4 (ADC_B3)
		20	GND	Analog Ground
		21	adc_VAC1	AC Voltage 1 (ADC_D0)
		22	adc_VAC2	AC Voltage 2 (ADC_D1)
		23	adc_VAC3	AC Voltage 3 (ADC_D2)
		24	N/C	Not Connected (ADC_D3)
		25	N/C	Not Connected (ADC_D4)
		26	GND	Analog Ground

**Appendix C Test Points on CPT-DFM2**

TEST POINT NAME	SIGNAL NAME	DESCRIPTION
TP1	+24V_ELV	+24V Input Supply to DC-DC Converter - Fused
TP2	GND_GATE	Gate Supply Ground
TP3	+12V_GATE	+12V Gate Supply
TP4	+0V_ELV	+0V Input Supply
TP5	+5V	+5V Digital Supply
TP6	+3.3V	+3.3V Digital Supply
TP7	+12V_DIG	+12V Digital Supply
TP8	+12V	+12V Analog Supply
TP9	AGND	Analog Ground
TP10	-12V	-12V Analog Supply
TP11	+2.5V	+2.5V Reference Voltage
TP12	+3.3V_A	+3.3V Analog Supply
TP13	AGND	Analog Ground
TP14	GND	Digital Ground

**Appendix D Texas Instruments Technical Manuals for Control Card MCU**

**TMS320F28075PTP Piccolo Microcontroller**

Texas Instruments Website: <http://www.ti.com/product/TMS320F28075/technicaldocuments>

Datasheet Document Number: SPRS902  
 Technical Manual Document Number: SPRUHM9

**TMS320F2837xSPTP**

Texas Instruments Website: <http://www.ti.com/product/TMS320F28377S/technicaldocuments>

Datasheet Document Number: SPRS881  
 Technical Manual Document Number: SPRUHX5

**TMS320F2837xDPTP**

Texas Instruments Website: <http://www.ti.com/product/TMS320F28377D/technicaldocuments>

Datasheet Document Number: SPRS880C  
 Technical Manual Document Number: SPRUHM8C

**ControlSuite**

Texas Instruments Website: <http://www.ti.com/tool/controlsuite>